



FUNDICIÓ DÚCTIL BENITO  
Tel. 93 852 10 00

# Madrid

DESIGNER:

MANUFACTURER: Fundicio Ductil Benito

DIMENSIONS: mm

SCALE: 1/20

UM330

REFERENCE

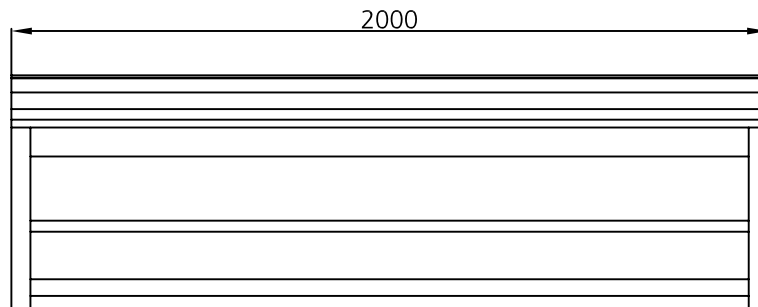
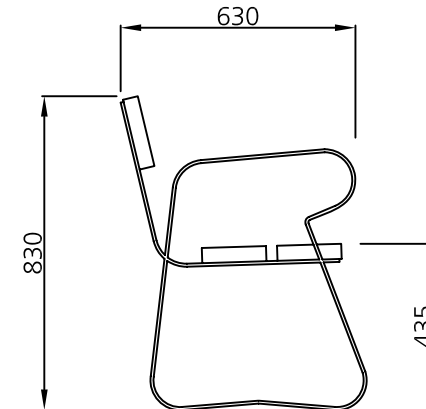
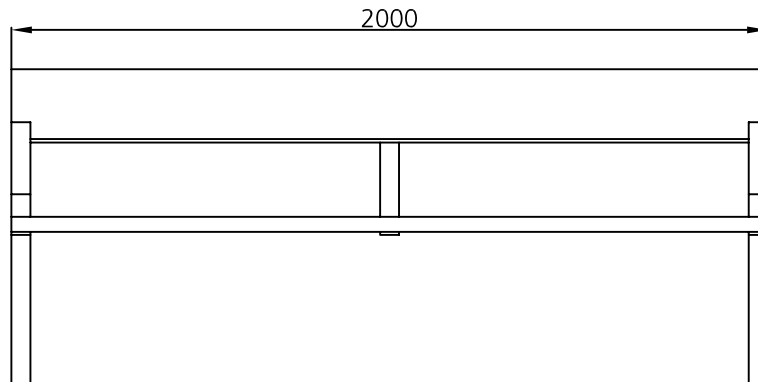

MATERIAL:

Legs and center reinforcement made of 50 x 8 mm steel plates. Stainless steel screws. Two tropical wooden boards of 170 x 40 mm for the seat and a 190 x 40 mm board for the backrest.

FINISHING:

Legs treated with brilliant black polyester paint (oven technique). Tropical wood treated with \*LIGNUS\* a preventive fungicide, insecticide and water proofed product. Mahogany wood colour finish.

RECOMMENDED ANCHORAGE:

M10 fixing bolts for anchoring to the ground, depending on the surface and the project.



FUNDICIÓ DÚCTIL BENITO  
Tel. 93 852 10 00

# ANCHORAGE DETAIL

DESIGNER:

MANUFACTURER:

DIMENSIONS: mm

SCALE:

REFERENCE

